

Much more than just cold air

Truma air conditioning systems

	Aventa eco	Aventa comfort	Saphir compact	Saphir comfort	Saphir comfort RC	Saphir vario
Power supply	230 V– 240 V, 50 Hz	230 V– 240 V, 50 Hz	230 V– 240 V, 50 Hz, 12 V*	230 V– 240 V, 50 Hz	230 V– 240 V, 50 Hz	230 V– 240 V, 50 Hz, 12 V*
Cooling output / heating output (heat pump)	1700 W	2400 W / 1700 W**	1800 W	2400 W	2400 W / 1700 W**	600 W, 1500 W, 2000 W
Current draw (230 V) cooling mode	2,8 A	4,2 A	2,8 A	4,2 A	4,2 A	1,7 A 3 A 4,4 A
Current draw (12 V) cooling mode	-	-	55 A	-	-	35 A, 62,5 A
Current draw heating mode	-	3,7 A	-	-	3,7 A	-
Starting current	20 A (150 ms)	28 A (150 ms)	15 A (150 ms)	20 A (150 ms)	20 A (150 ms)	20 A (150 ms)
Weight	28 kg	33 kg	20 kg	22,5 kg	23,5 kg	28 kg
Dimensions mm (L x H x W)	Outside: 1008 x 660 x 248 Inside: 670 x 523 x 46	Outside: 1008 x 660 x 248 Inside: 670 x 523 x 46	560 x 400 x 290	710 x 400 x 290	628 x 400 x 290	800 x 550 x 200
Roof cut-out mm (L x B)	380 - 400 x 350 - 400	380 - 400 x 350 - 400	-	-	-	-

* with TG 1000 sinus.

** Heating mode is only available at an outdoor temperature of approx. 4 °C.

Discover more at:
www.truma.com

Truma Gerätetechnik GmbH & Co. KG
Wernher-von-Braun-Straße 12
85640 Putzbrunn
Germany
Phone +49 (0)89 4617-2142
service@truma.com

More comfort on the move

Y00508 • 02/2013 • 97' • INT-GB • 5' • KOE



Truma
air conditioning systems
New with Aventa eco and
Saphir comfort RC

More comfort on the move

Much more than just cold air

Truma air conditioning systems

To ensure that you feel comfortable and can enjoy and relax in your free time, it is important that the climate inside your caravan or motorcaravan is the best it can be. The Truma air conditioning systems were specially designed for use in your mobile home with this in mind. Place your trust in the proven Truma technology and excellent Truma service for air conditioning in your recreational vehicle.



Truma air conditioning technology: a leader for many years



Fastest cooling and most convenient air distribution



Particularly light to allow additional loads



Pleasantly quiet



Economic current draw – can be used on almost all European camping sites



Almost maintenance-free



Highly efficient thanks to the higher output combined with low current draw

Truma air conditioning convenience as required

Find your own personal well-being climate

The powerful air conditioning systems Saphir and Aventa from Truma offer sophisticated technology. They cool and dehumidify the air, thereby providing a very pleasant room climate.

The following should be noted when selecting an air conditioning unit: The larger the room, the warmer and damper the climate; the less shade in the vehicle, the more cooling output is required. You will find the right system to meet your needs among the various powerful Truma models.

The following rule of thumb applies to guarantee even cooling within the vehicle:

Vehicle up to 5.5 m in length	Saphir compact
Vehicle up to 6.0 m in length	Saphir vario Aventa eco
Vehicle up to 6.5 m in length	Saphir comfort (RC)
Vehicle up to 7.5 m in length	Aventa comfort

The integrated heat pump in the Aventa comfort and Saphir comfort RC provides an additional heating function for mid-season periods.

Finding the right Truma air conditioning system to meet your needs depends on a number of factors. Visit our homepage www.truma.com and use the decision tool to facilitate your product selection.

Aventa comfort

The top star among rooftop air conditioning units



- Strong cooling and very high air output with 2400 W
- Highest efficiency levels in cooling and heating mode
- Very light, weighing just 33 kg
- Especially quiet cooling thanks to sleep function
- Practical timer function
- Fast and simple retrofitting

Aventa eco

Cooling can be this efficient



- Cools with a powerful 1700 Watt
- Very low current draw of just 2.8 A
- The lightest in its class weighing just 28 kg
- Especially quiet cooling thanks to sleep function
- Practical timer function
- Fast and simple retrofitting

Air distributor grey

The modern one

Air distributor cream

The classic one



- Very flat inside the vehicle for more through-space
- Technically optimised to ensure very quiet air conditioning
- Honeycomb-shaped air filter system cleans the inner air
- Dimmable LED ambient lighting
- Many options for controlling and dosing the air current

These are the results of the promobil comparison test with the Dometic B 2600 in issue 09/2011:

„The Aventa comfort marks another success for Truma. Its cooling output is fantastic. In terms of power consumption and air distribution, it sets very high standards in its class - and at a very competitive price.“



The new sealing frame is available exclusively for the Aventa rooftop air conditioning systems

- Permanent seal to the inside of the vehicle
- For rooftop thicknesses from 25 – 110 mm
- Ideal, if a skylight has been fitted previously



Truma Saphir comfort RC

Cooling and heating in one device



NEW!
Cooling
and
heating

- Very powerful cooling with 2400 W
- In heat pump mode, it heats with up to 1700 W
- Automatic heating/cooling
- The smallest and lightest in its class
- Practical timer function

Truma Saphir comfort

Light, quiet, powerful



- Very powerful cooling with 2400 W
- The lightest in its class: weighing just 22.5 kg
- Practical timer function



Truma Saphir compact

Small, light, economic



- Cools with 1800 W
- Very low current draw of just 2.8 A
- Uniquely light: just 20 kg
- Especially quiet in the sleep function
- Even cools when on the road*
- Practical timer function

* With inverter TG 1000 sinus

Truma Saphir vario

Intelligent air conditioning technology,
ideal for motorcaravans



- Three variable output levels (600 / 1500 / 2000 W)
- Maximum comfort with just 28 kg
- Even cools when on the road and independently at a standstill
- Automatic voltage recognition for easy cooling convenience
- Practical timer function

* With inverter TG 1000 sinus

Unrivaled
worldwide: the only
air conditioning unit that
can be fitted into the
false floors of many
motorcaravans

A good climate has:

original Truma accessories for Saphir air conditioning systems

Air distribution

Modular system

- Components that are precisely tuned to each other
- For setting the air quantity and flow direction
- For perfect circulation and individual well-being climate
- Can also be modified or expanded after installation



Sound dampers

- Reduces the air flow noise inside the vehicle by 50 %
- Two sound dampers can even reduce the noise level by 90 %
- Can be easily integrated into the cold air flow

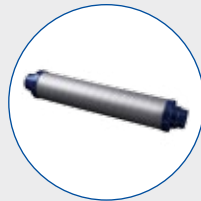

Blow-out channel

- Reduces the outside noise from the air conditioning system
- Is fitted below the vehicle
- For Saphir compact, comfort and vario



Inverter

TG 1000 sinus

- For independent cooling comfort
- Power supply in the stand above the battery (Saphir vario)
- Power is supplied during the journey via the dynamo (Saphir compact and Saphir vario)



Well-being is a matter of choice

Saphir installation suggestions

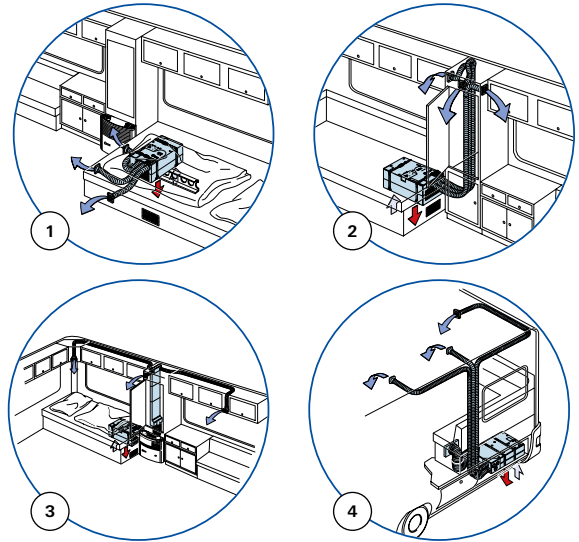

- 1 **Eco installation solution:** simple, inexpensive and fast installation. Very easy installation if the air outlets remain at the bottom.
- 2 **Convenience installation solution:** functional and convenient. The cold air is fed upwards via pipes and distributed evenly throughout the inside of the vehicle without causing draughts.
- 3 **Luxury installation solution:** ultimate living and sleeping comfort. The expanded cold air system allows the conditioned air to be distributed individually throughout the recreational vehicle.
- 4 **Vario installation solution:** using the false floor. Space-saving installation into the false floors of motorcaravans is only possible with the Truma Saphir vario.

Truma will be happy to advise you on how to install your air conditioning system.
Just call: +49 (0)89 4617-2142